

## INSTALLATION AND MAINTENANCE INSTRUCTIONS

# MRI-4070-M MULTI-ISOLATOR MODULE

### ABOUT THIS MANUAL

This manual is included as a quick reference for installation. For further information on the use of this device with a FACP, please refer to the panel's manual.

**Note:** This manual should be left with the owner or operator of this equipment.

### DESCRIPTION

The MRI-4070-M multi-isolator module provides 8 isolator sections, each being electrically isolated from the others. The MRI-4070-M enables the SLC (signalling line circuit) communication loop to continue operating when a short circuit occurs on one section of the loop. All circuits are power limited and supervised.

The MRI-4070-M is compatible with MR-400, MR-401 and MMX™-4000 fire alarm control panels and is designed to meet UL 864, 10th Edition and ULC S527, 4th Edition requirements for devices.

On each section in use, an LED indicator blinks to indicate a normal condition and turns on solid during a short circuit condition. Each section will automatically restore the protected communication loop section to the normal condition when the short circuit is removed. The module is a hardware only device that does not require an address. There are no limits on the number of MRI-4070-M units installed on the SLC as long as total loop current limit is respected. This is a low current device. Any unused section can be left unconnected without affecting other sections. All connections to the MRI-4070-M are done through plug-in terminal blocks.

Each isolator section can isolate an SLC that has a maximum load of 0.4 A and a minimum load of 0.0 A. The maximum resistance that will switch the isolator from closed to open is 10 Ω.

### Accessories

<b>MMX-BB-4002R</b>	Back Box and Red Door for 1 or 2 MRI-4000-M Series Modules
<b>MMX-BB-4006R</b>	Back Box and Red Door for up to 6 MRI-4000-M Series Modules

**FIGURE 1: MODEL FRONT AND SIDE VIEW**

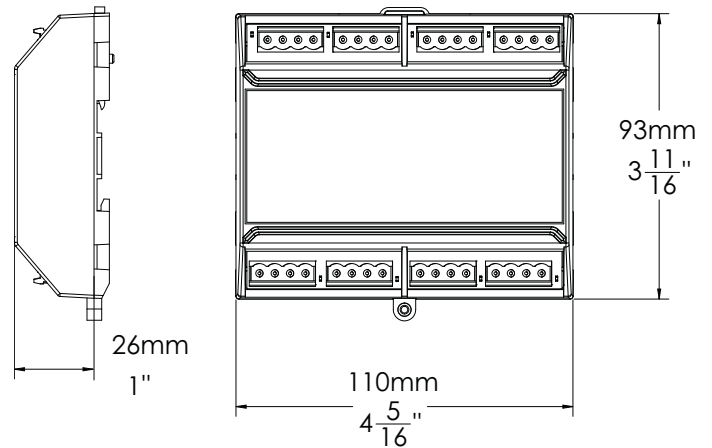

### SPECIFICATIONS

Normal Operating Voltage:	UL tested 15 to 29VDC UL rated 17.64 to 26.4 VDC
Activation Current:	9.5 mA per activated section
Standby Current:	0.56 mA per used section
Temperature Range:	0°C to 49°C (32°F to 120°F)
Humidity Range:	10% to 93% non-condensing
Dimensions:	110 mm x 93mm (4 5/16 x 3 11/16 in)
Terminal wire gauge	12-22 AWG

## KEY COMPONENTS

**FIGURE 2: MULTI-ISOLATOR MODULE ASSEMBLY COMPONENTS**

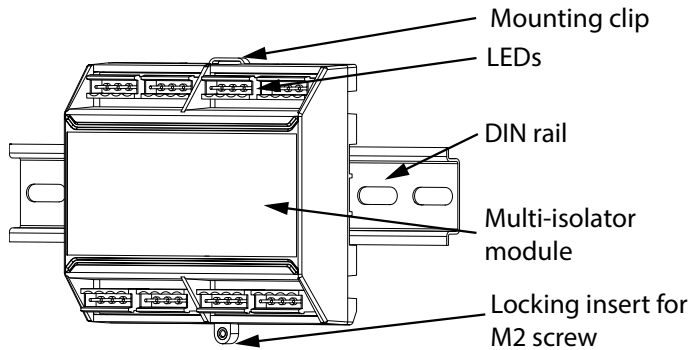

The MRI-4070-M multi-isolator module as shown in figure 2 is designed to fit on a DIN rail. The M2 screw can be used to lock its position.

**Note:** This device must be installed as per applicable requirements of the authorities having jurisdiction.

## MOUNTING

Units in the multi module series can be mounted on a top-hat style 35mm wide DIN rail included in the Secutron listed enclosures:

- MMX-BB-4002R for 1 or 2 modules (see document LT-6736SEC) or equivalent Listed enclosure of the same size or larger (see document LT-6749).
- MMX-BB-4006R for up to 6 modules (see document LT-6736SEC) or equivalent Listed enclosure of the same size or larger (see document LT-6749).

1. Hook the multi module device onto the bottom of the DIN rail with three teeth.
2. Push the mounting clip upward with a flat screwdriver.
3. Push the multi module device onto the DIN rail and release the clip.

**FIGURE 3: MOUNTING DIAGRAM**

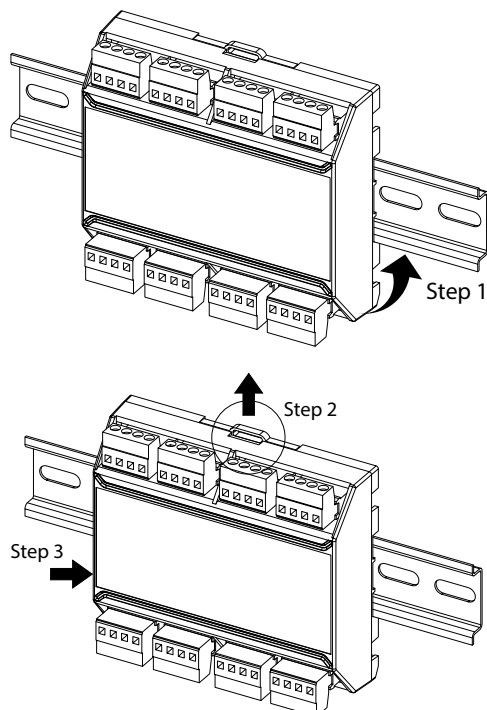

## WIRING

Before installing this device, seek guidance from the compatible control panel instructions for the device's operation modes and the configuration requirements. It is recommended to disconnect the SLC line before performing installation or service.

**FIGURE 4: DEVICE CONNECTION – TYPICAL ISOLATOR WIRING FOR TWO CIRCUITS**

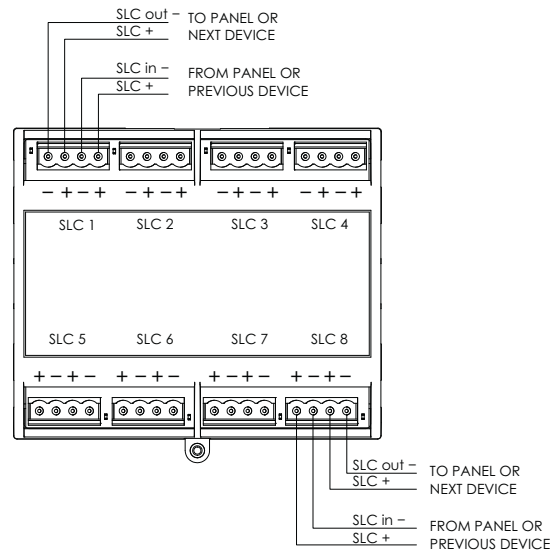

All connections to field wiring are done with plug-in terminal blocks.

**Use the information in this document to determine the total current draw of the devices. In all cases, the installer should consider the voltage drop to ensure that the last device on the circuit operates within its rated voltage. Please consult the FACP documentation for more information.**

## RELATED DOCUMENTS

- LT-6736SEC MMX-BB-4002R and MMX-BB-4006R Installation Instructions
- LT-6749 MGC-4000-BR DIN Rail Kit Installation Instructions