

INSTALLATION AND MAINTENANCE INSTRUCTIONS

MRI-4021 MULTI-SENSOR DETECTOR

MRI-4021-ISO MULTI-SENSOR DETECTOR

ABOUT THIS MANUAL

This manual is included as a quick reference for installation. For further information on the use of this device with a FACP, please refer to the panel's manual. For more information regarding maintenance, testing, spacing, and locating detectors, please refer to the LT-9420SEC MRI-4000 series detector technical bulletin.

Note: This manual should be left with the owner/operator of this equipment

DETECTOR DESCRIPTION

The MRI-4021 smoke detector continuously checks air obscuration and reports it to the Fire-Alarm panel using a fully digital communication protocol. It can also measure ambient temperature and can be set to report an alarm when sampled temperature exceeds 135°F (57°C). Excessive temperature rises can also be reported if the detector is configured for rate-of-rise operation. The MRI-4021 must be used with a MRI-4000 series compatible control panel. Operational mode and levels are selected at the Fire alarm panel through the panel configuration tool. It also has a remote output that can be controlled by the panel. Please see specifications for compatible devices that can use the remote output feature. These devices are listed to UL 268 7th Edition.

Note: MRI-4021-ISO is equipped with a bi-directional short-circuit isolator to help protect against wiring faults that may otherwise result in a loop failure.

Note: Detectors with built-in isolators (ending with -ISO) will add some resistance to the SLC loop: The total allowable loop resistance of 40 Ohms must be reduced by 0.22 Ohms for each device with a built-in isolator.

Before installing this device please thoroughly read this manual and refer to the applicable codes for guidance on location, spacing and acceptable use. Also seek guidance from the compatible control panel instructions for the device operation modes and the configuration requirements.

Note: If the detector is used with the remote indicator, then the voltage value of the detector must be at least 18V as the indicators do not operate below 18V.

FIGURE 1: DETECTOR FRONT



SPECIFICATIONS

Standard	UL 268 7th Edition, UL 521, CAN/ULC-S529 and CAN/ULC-S530
Normal Operating Voltage:	15 to 30VDC
Maximum Alarm Current (LED on):	3.2mA (LED on)
Standby Current:	160µA (LED flashing)
Temperature Range (no alarm):	32°F to 100°F (0°C to 37.8°C)
Humidity:	10% to 93% Non-condensing
Dimensions:	4 1/4" Diameter, 1 3/4" Height
Mounting:	4" square by 2 1/8" deep box
Accessories:	MIX-4090 Programmer MRI-4001/4002 Detector Base RA100Z Remote LED
Wiring range on all terminals:	22 to 12 AWG

INSTALLATION

This detector must be installed on a ceiling or wall using a compatible base. SLC line and remote output connections for the most common base MRI-4001 are shown in figure 2. A twisted pair cable should be used for the SLC line. If a shielded cable is used, connect the shields to the proper terminal on the base. Do not connect shields to earth ground. If a ground continuity wire is required by the local code, it should be a separate conductor. Please note that shielded cables may reduce the SLC loop length that can be achieved due to their high capacitance.

The detector address should be programmed using the MIX-4090 hand-held device before inserting the detector on the base. Addresses 1 to 240 can be used for any device on a SLC loop. Each device on a loop must have a unique address.

A breakaway tab inside the base can be inserted in the outer rim of the base to visibly identify each detector with their address. See figures 2 and 4. The detector can then be placed on the base using the following steps:

1. Position the detector centrally on its adapter base ensuring it is level.
2. Rotate clockwise applying gentle pressure. The detector will drop into its keyed location.
3. Continue to rotate clockwise a few degrees until the detector has fully engaged in the adaptor base.
4. When the detector is firmly engaged, check the alignment of the raised reference marks on the detector and on the base (figure 4).

IMPORTANT NOTES ON DETECTOR INSTALLATION

Disconnect loop power before installing the detector.

This detector comes with a dust cover to protect the device during shipping and when first installed. It is not intended to provide complete protection against contamination, therefore, detectors should be removed from their base before construction, major re-decoration or other dust producing work is started. Dust covers must be removed before the system becomes operational.

Heat detectors should be installed away from normal heat sources. Do not use in locations where ambient temperature is within 20°F (10°C) of the alarm setting. Long term ambient temperature should not exceed 120°F (49°C).

When configured for rate of rise operation, do not use heat detectors in locations such as an heated building entrance where large temperature swings can be expected.

Smoke detectors are not to be used with detector guards unless the combination has been evaluated and found suitable for that purpose.

When duplicate terminals are not provided to facilitate monitoring of the installation wiring connections, and there is no provision to prevent looping an unbroken wire around or under a terminal, the word "CAUTION" and the following or equivalent text in letters not less than 2.38 mm (3/32 inch) high shall be included on the installation drawing: "FOR SYSTEM MONITORING - FOR TERMINALS "Loop out (+)" AND "Remote Device (+)", DO NOT USE LOOPED WIRE UNDER TERMINALS. BREAK WIRE RUN TO PROVIDE MONITORING OF CONNECTIONS.

FIGURE 2: DETECTOR WIRING

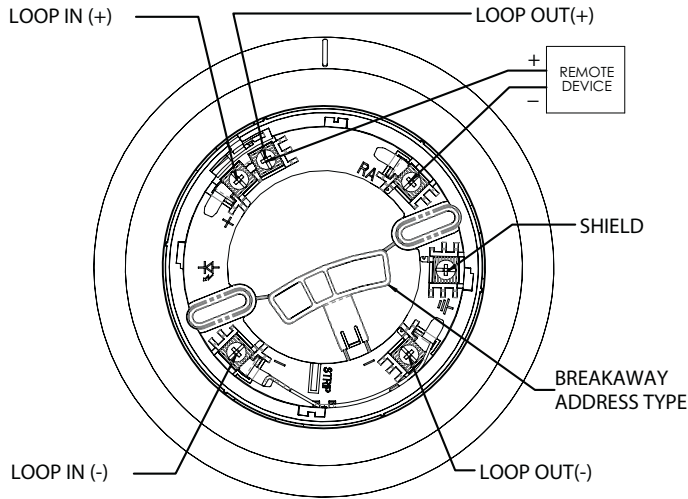

FIGURE 3: LOOP WIRING

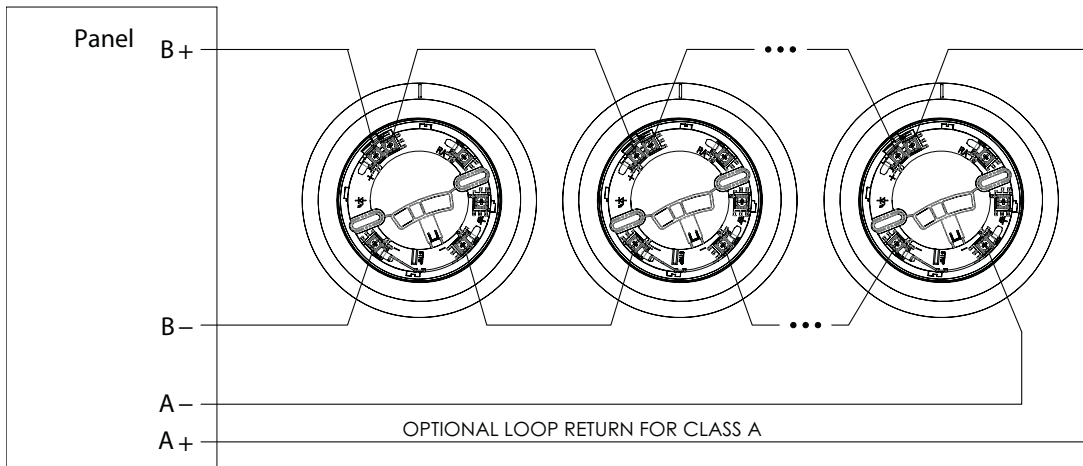
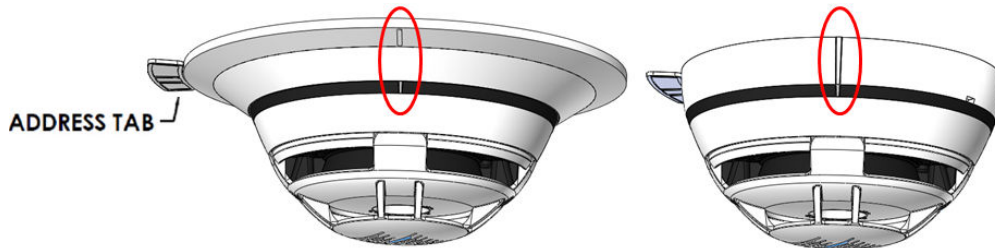

FIGURE 4: ALIGNMENT MARKS



Detector LED Colors	
Alarm	Red (Steady on)
Air and Temperature Sampling	Green (Flash)
Fault	Yellow (Steady on)

Sensitivity Level	Typical	Note
HOT	2.25 %/feet	Most sensitive level
Medium	2.50 %/feet	
COLD	2.75 %/feet	Least sensitive level

Heat detection settings	
135°F (57°C)	
135°F with rate of rise as per UL268	