

INSTALLATION AND MAINTENANCE INSTRUCTIONS

MRI-4003-S Sounder Base

CAUTION / ATTENTION
 DO NOT PAINT OR ALTER
 FACTORY APPLIED FINISH IN ANY WAY
 NE PAS PEINDRE OU MODIFIER
 LA FINITION ORIGINALE

ABOUT THIS MANUAL

This manual is included as a quick reference for installation and should be left with the owner/operator of this equipment. For further information on the use of this device with a FACP, please refer to the panel’s manual.

Note: This manual should be left with the owner/operator of this equipment.

SOUNDER BASE DESCRIPTION

The MRI-4003-S sounder base horn is designed to meet UL268/ULC S529 requirements for smoke detector, UL521/ULC S530 requirements for heat detector, and UL464/ULC S525 requirements for audible notification appliances.

The MRI-4003-S is providing localized alarm sounding capability for the MRI-4000 family of fire detection devices. They can be used in place of external sounders to minimize installation cost and footprint while allowing individual control of signal rate and on-off state for each device. The MRI-4003-S must be used with a compatible Secutron control panel. Operational mode and levels are selected at the Fire alarm panel through the panel configuration tool.

The MRI-4003-S produces an alarm signal at SPL of Table 2.

Figure 1 MODEL FRONT AND SIDE VIEW WITH MRI-4000 SERIES DETECTOR

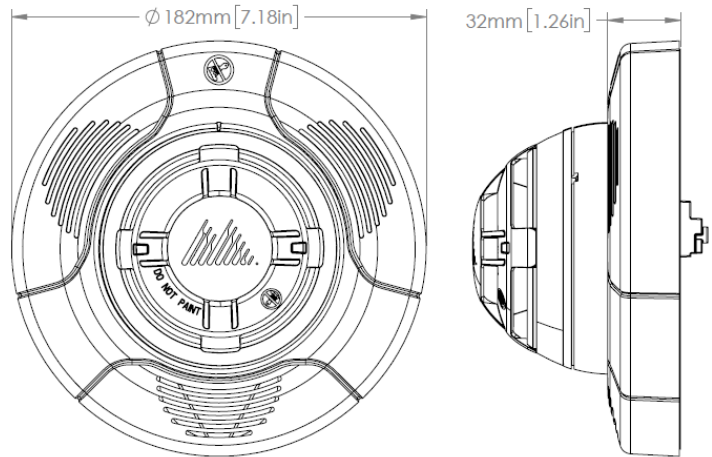

Table 1 SPECIFICATION

Operating temperature	0°C to 49°C (32°F to 120°F)
Humidity range	0% to 93%
Nominal voltage	Regulated 24VDC/VFWR
SLC Standby Current	1.56mA
SLC Alarm Current	2.34 mA
Base Diameter	182mm [7-3/16 in]
Base Height	32mm [1-1/4 in]
Terminal wire gauge	12-22 AWG

KEY COMPONENT

Figure 2 SOUNDER BASE ASSEMBLY COMPONENTS

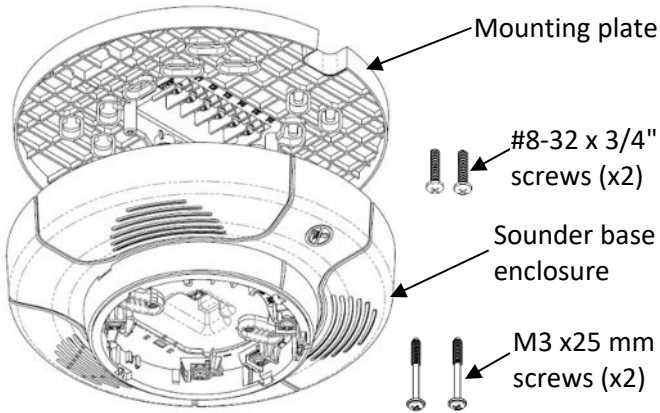
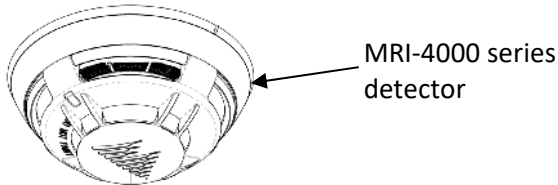

Figure 3 MRI-4000 SEREIS DETECTOR



A mounting plate in figure 2 is mounted first on the electrical box and all wiring is done on integral screw connectors. The connections are apparent and can be visually inspected before the sounder base itself is mounted. Then, the enclosure containing the electronics, the sounder and the detector base can be plugged-in and secured.

Note: This device should be installed as per applicable requirements of the authorities having jurisdiction.

WIRING

Before installing this device seek guidance from the compatible control panel instructions for the device operation modes and the configuration requirements. It is recommended to remove power from SLC and NAC lines before performing installation.

Figure 4 WIRING TABS

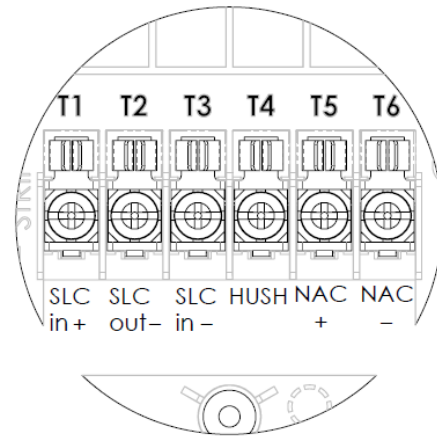
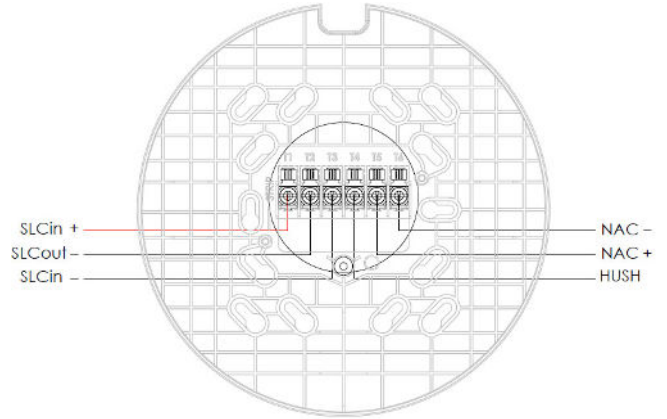

Use the information in this document to determine the total current draw of the devices. The total current draw of the devices must not exceed the NAC output capacity of the panel. In all cases, the installer should consider the voltage drop to ensure that the last device on the circuit operates within its rated voltage. Please consult fire panel installation manual for guidance on wire resistance and length. For maximum strobe operating current, please refer to Table 4.

Do not loop signal circuit field wires around terminals. Electrical supervision requires wire run to be broken at each end.

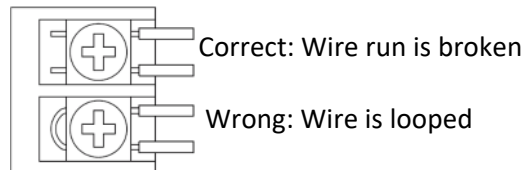
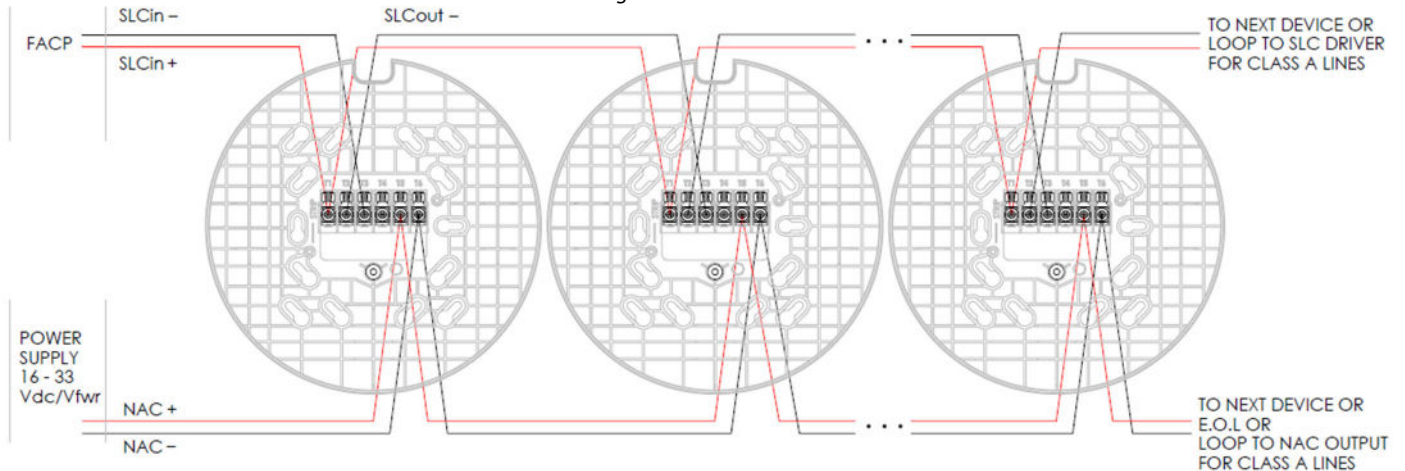

Figure 5 DEVICE CONNECTION



Note: Wiring must be in accordance with CSA C22.1, Canadian Electrical Code, Part I, Safety Standard for Electrical Installations, section 32 and/or NFPA 70.

CAUTION

FOR SYSTEM SUPERVISION, FOR ALL TERMINAL TAPS, DO NOT USE LOOPED WIRE UNDER TERMINALS. BREAK WIRE RUN TO PROVIDE SUPERVISION OF CONNECTIONS.

ATTENTION

NE PAS UTILISER DE FILS EN BOUCLE SOUS LES BORNES. POUR FOURNIR UN BON SUIVI DES CONNEXIONS. INTERROMPRE LA CONTIUITÉ DES CÂBLES.

MOUNTING

Secutron recommends spacing speaker strobe appliances in compliance with CAN/ULC S524 and/or NFPA72.

The mounting plate is compatible with 3" by 2" single gang device boxes, 3-3/4" by 4" double gang boxes, 4" by 2" single gang utility boxes, standard 4" by 4" boxes, and standard 4" octagon boxes.

1. Attach the mounting plate to electrical box with two mounting #8-32 x 3/4" screws.
2. Slide down the sounder base enclosure until the connection blades touch the clips on the mounting plate.
3. Secure the mounting plate with securing M3 x25 mm screws.

Figure 6 MOUNTING DIAGRAM

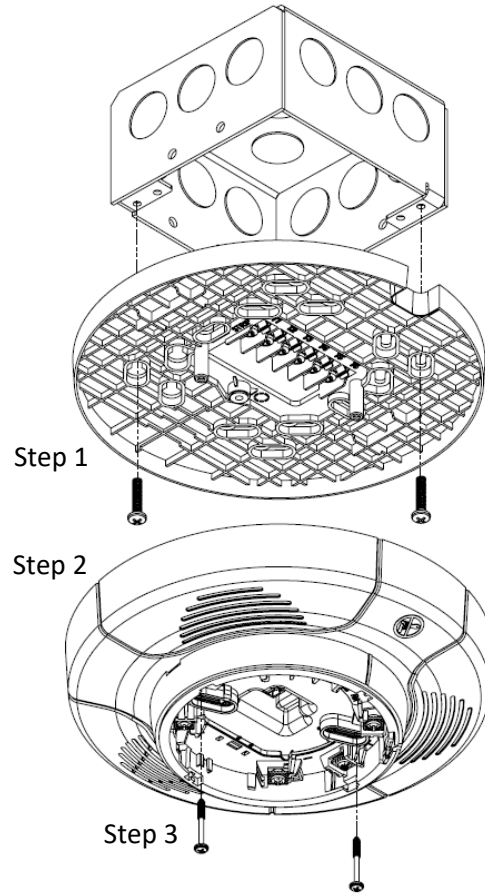

MOUNTING DETECTOR

If the detector type and address has be visible from the outside, break the address tab inside the detector base and insert it in the outer rim of the base. See figures 7.

Figure 7 ADDRESS TAB INSERT

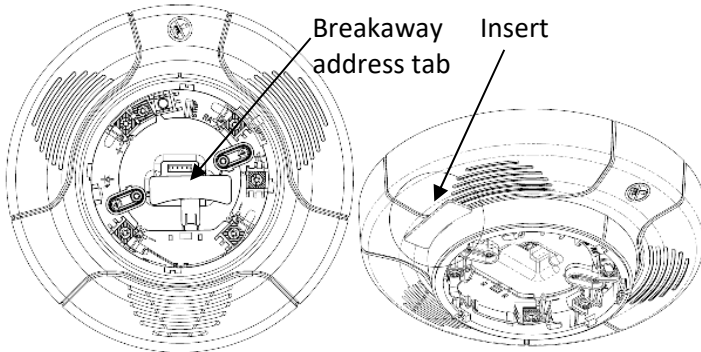

The detector can then be placed on the top base using the following steps (figure 8):

1. Position the detector centrally on its adapter base ensuring it is level.
2. Rotate clockwise applying gentle pressure. The detector will drop into its keyed location.
3. Continue to rotate clockwise a few degrees until the detector has fully engaged in the adapter base.
4. When the detector is firmly engaged, check the alignment of the raised reference marks on the detector and on the base (figure 9).

Figure 8 MOUNTING DETECTOR

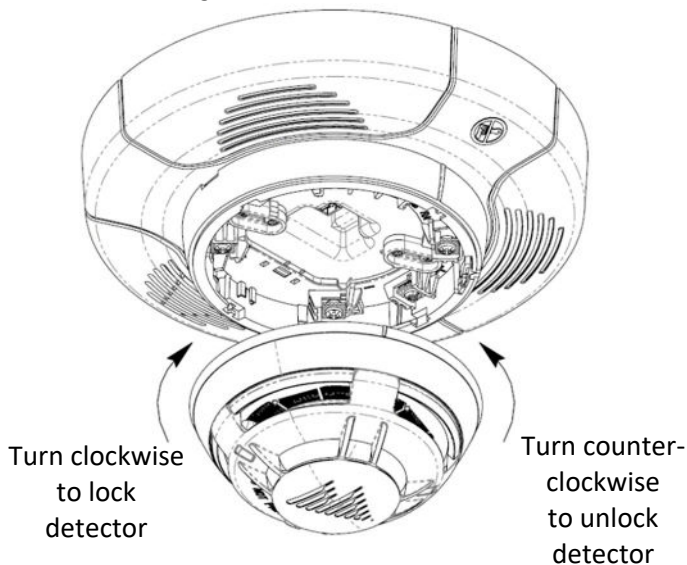
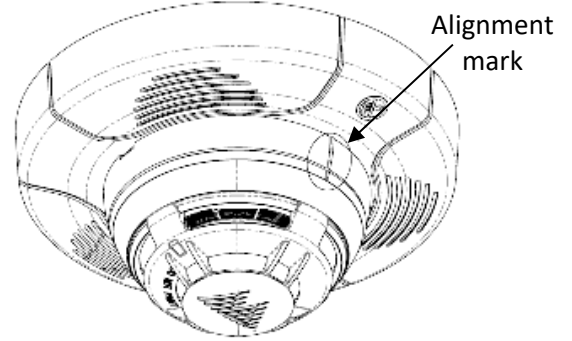

Figure 9 DETECTOR ALIGNMENT MARK



AUDIBLE RATINGS

Table 2 SOUND PRESSURE LEVEL OUTPUT

MRI-4003-S							
Sound Pattern	Volume	UL Reverberant (dBA@10ft)					
		16 VDC	Regulated 24 VDC	33 VDC	16 VFWR	Regulated 24 VFWR	33 VFWR
Temporal	High	83.8	84.5	83.8	84.2	84.6	83.6
	Low	79.3	81.1	81.5	81.0	82.5	82.3
Continuous	High	83.8	84.5	83.8	84.2	84.6	83.6
	Low	79.3	81.1	81.5	81.0	82.5	82.3
20 BPM	High	83.8	84.5	83.8	84.2	84.6	83.6
	Low	79.3	81.1	81.5	81.0	82.5	82.3
March	High	83.8	84.5	83.8	84.2	84.6	83.6
	Low	79.3	81.1	81.5	81.0	82.5	82.3

MRI-4003-S							
Sound Pattern	Volume	ULC Anechoic (dBA@3m)					
		16 VDC	Regulated 24 VDC	33 VDC	16 VFWR	Regulated 24 VFWR	33 VFWR
Temporal	High	90.6	91.5	90.8	91.2	91.7	90.5
	Low	86.1	88.2	88.5	88.0	89.5	89.2
Continuous	High	90.6	91.5	90.8	91.2	91.7	90.5
	Low	86.1	88.2	88.5	88.0	89.5	89.2
20 BPM	High	90.6	91.5	90.8	91.2	91.7	90.5
	Low	86.1	88.2	88.5	88.0	89.5	89.2
March	High	90.6	91.5	90.8	91.2	91.7	90.5
	Low	86.1	88.2	88.5	88.0	89.5	89.2

Table 3 DIRECTIONAL SOUND CHARACTERISTICS

MRI-4003-S		
HORIZONTAL ANGLE	VERTICAL ANGLE	OSPL (dBA)
+/- 34	+/- 36	-3
+/- 41	+/- 42	-6
+/- 90	+/- 90	-10 in horizontal -7 in vertical

OPERATING RMS CURRENTS

Table 4 OPERATING RMS CURRENTS (mA)

MRI-4003-S			
Sound Pattern	Volume	Regulated 24VDC	Regulated 24VFWR
Continuous	High	22	44
	Low	19	41
Temporal	High	22	44
	Low	18	41
20 BPM	High	21	45
	Low	18	41
March	High	21	46
	Low	18	41

The sounder base is capable of producing a variety of tone patterns, including the distinctive three-pulse temporal pattern (ANSI Temporal 3) fire alarm signal now required by NFPA 72 for commercial and residential applications and is configured in this default mode. The device offers two volume levels: low and high. The available tones are Continuous, ANSI Temporal 3, 20 BPM, and March. Refer to the appropriate fire alarm control panel manual for more information on selection of these tones. NOTE: For NFPA 72 Installations, the Temporal 3 tone at high volume should be used for emergency and public mode evacuation. The use of other tone styles and low volume level will be at the discretion of the local Authority Having Jurisdiction (AHJ).

Model Numbers

MRI-4003-S 4000 SERIES SOUNDER BASE

Accessories

4000 SERIES DETECTORS:

- MRI-4010** Non-isolated photoelectric detector
- MRI-4011** Non-isolated photoelectric detector Rev7
- MRI-4010-ISO** Isolated photoelectric detector
- MRI-4011-ISO** Isolated photoelectric detector Rev7
- MRI-4020** Non-isolated photoelectric/heat detector
- MRI-4021** Non-isolated photoelectric/heat detector Rev7
- MRI-4020-ISO** Isolated photoelectric/heat detector
- MRI-4021-ISO** Isolated photoelectric/heat detector Rev7
- MRI-4030** Non-isolated heat detector
- MRI-4030-ISO** Isolated heat detector
- CH-1298** NAC shorting clip