

1.1 Installation

The QAS-2X8 mounts on the rightmost side of the QX-mini(-BP) or AUDMAX-MASTER(-BP) board using four spacers. The QAS-2X8 uses a ribbon cable for connections and power.



Note: Ensure ALL AC and battery connections are disconnected before attempting to install or remove any component. Otherwise, board damage may occur.

1. Replace one standoff for each screw on the right side of the QX-mini(-BP) or AUDMAX-MASTER(-BP) board as shown in Figure 1.
2. Attach ribbon cable between P7 on the QX-mini(-BP) or AUDMAX-MASTER(-BP) board to P1 on QAS-2X8 audio zone splitter board.
3. Place QAS-2X8 board so its screw holes align with the standoffs.
4. Secure QAS-2X8 using four screws.

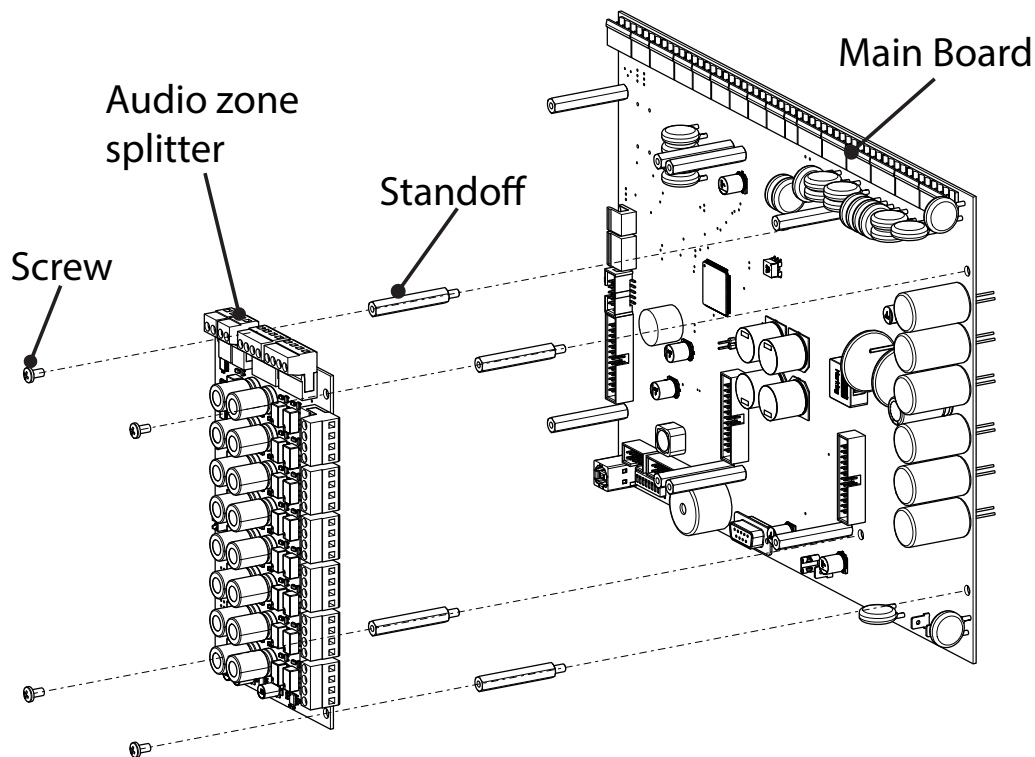

Figure 1 Installing the audio zone splitter module

1.2 Wiring

The terminals on the QAS-2X8 are shown below and are described in Table 1.

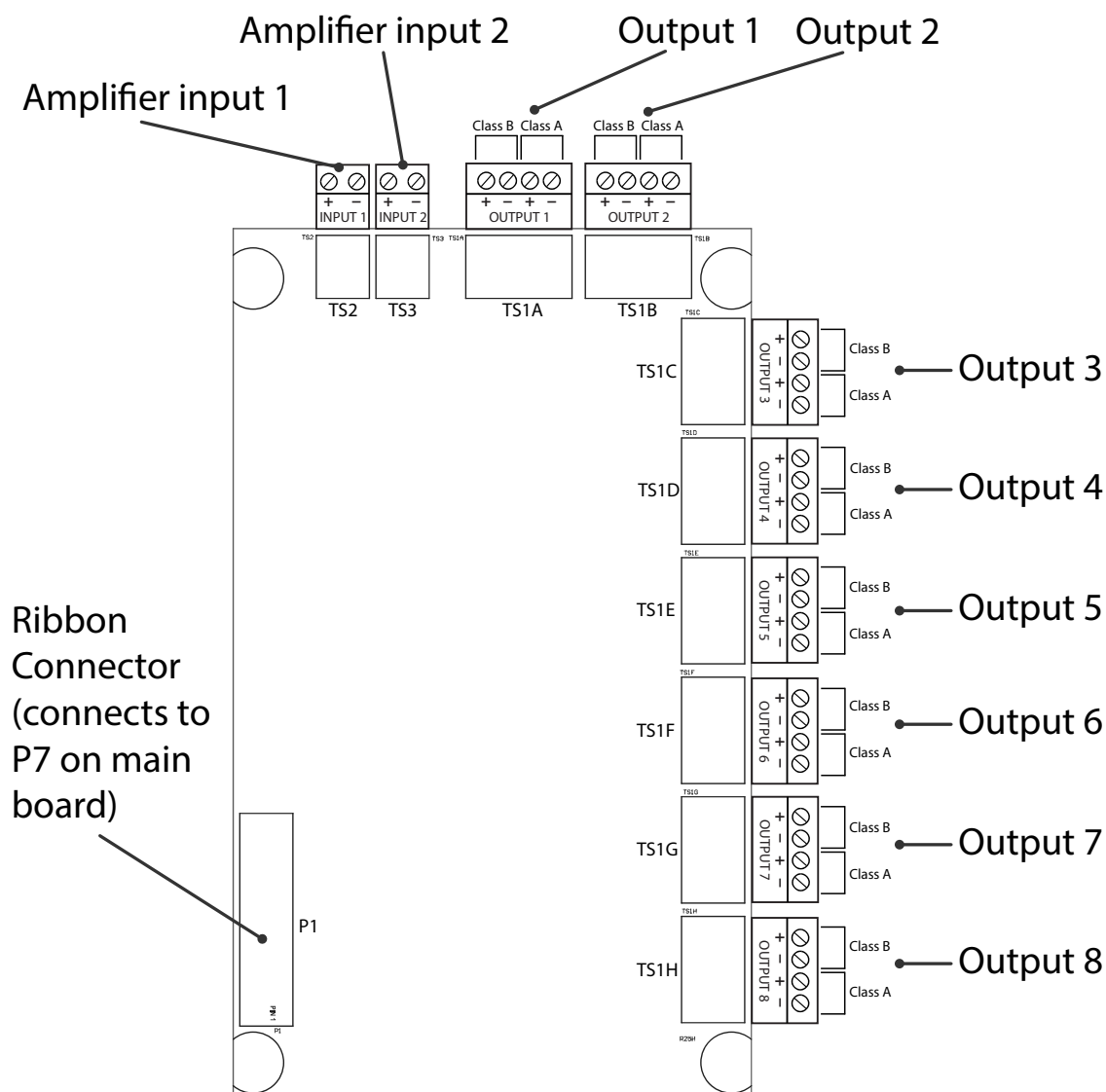

Figure 2 QAS-2X8 audio zone splitter module connections

Table 1 QAS-2X8 audio zone splitter module terminals

Terminal	Description
P1	Ribbon cable terminal to P7 on main board.
TS2	Amplifier input 1 terminals.
TS3	Amplifier input 2 terminals.
TS1A - TS1H	Output terminals 1-8 for audio zones.

For complete wiring instructions, refer to LT-2077 or LT-2077SEC.