

## INSTALLATION AND MAINTENANCE INSTRUCTIONS MIX-4070 SLC SHORT CIRCUIT ISOLATOR

### ABOUT THIS MANUAL

This manual is included as a quick reference for installation. For further information on the use of this device with a FACP, please refer to the panel's manual.

Note: This manual should be left with the owner/operator of this equipment.

### MODULE DESCRIPTION

The MIX-4070 SLC Short Circuit Isolators enable part of the communication loop to continue operating when a short circuit occurs on it. An LED indicator blinks in the normal condition and turns on during a short circuit condition. Only LED of devices next to the short are steady on for easy identification of faulty SLC section. The module will automatically restore the entire communication loop to the normal condition when the short circuit is removed. The module is a hardware only device that does not require an address. There are no limits on number installed on the SLC as long as total loop current limit is respected. This is a low current device.

### SPECIFICATIONS

Normal Operating Voltage:	15 to 30VDC
Activation Current:	9.6mA
Standby Current:	0.6mA
Temperature Range:	32F to 120F (0c to 49C)
Humidity:	10% to 93% Non-condensing
Dimensions:	4 5/8" H x 4 1/4" W x 1 1/8" D
Mounting:	4" square by 2 1/8" deep box
Accessories:	BB-400 Electrical Box
Wiring range on all terminals:	22 to 12 AWG

FIGURE 1 ISOLATOR MODULE WIRING:

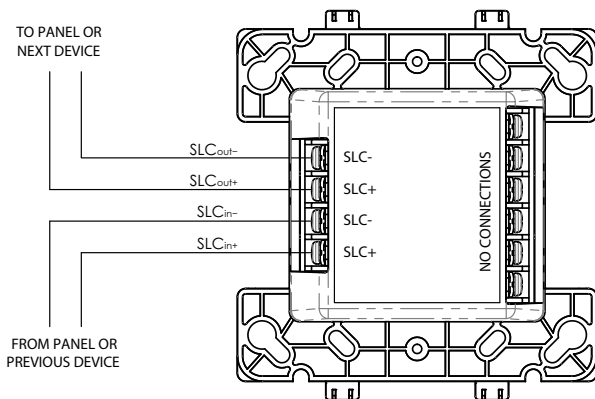

### MOUNTING

Notice: You must disconnect power from the system before installing the module. If this unit is being installed in a system that is currently operational, it is necessary to inform the operator and the local authority that the system will be temporarily out of service.

The MIX-4070 module is intended to be mounted in a standard 4" square back-box (see Figure 2). The box must have a minimum depth of 2 1/8 inches. Surface mounted electrical boxes (BB-400) are available from Mircom.

NOTE: The number of devices that may be installed between fault isolator modules will vary depending upon the types of devices being isolated. Contact the fire alarm control panel manufacturer for the isolator load ratings of individual devices.

FIGURE 2 MODULE MOUNTING:

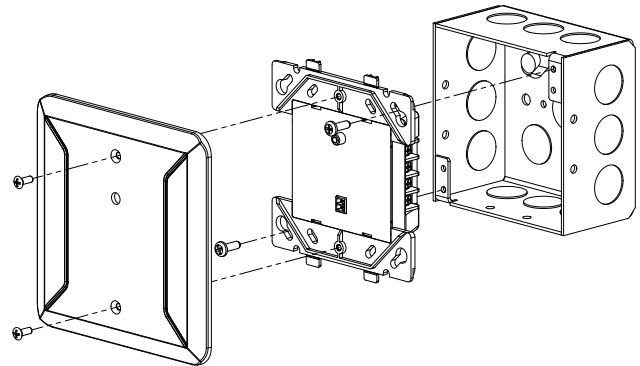

### WIRING:

Note: This device should be installed as per applicable requirements of the authorities having jurisdiction. This device shall be connected to power limited circuits only.

1. Install module wiring in accordance with the job drawings and the wiring diagram in Figure 1.
2. Secure module to electrical box (supplied by installer).