

INSTALLATION AND MAINTENANCE INSTRUCTIONS MRI-4001 / 4002 DETECTOR BASE

ABOUT THIS MANUAL

This manual is included as a quick reference for installation. For further information on the use of this device with a FACP, please refer to the panel's manual.

Note: This manual should be left with the owner/operator of this equipment.

DETECTOR BASE DESCRIPTION

The MRI-4001 and MRI-4002 bases are used to interface MRI-4000 series detectors to the SLC line and remote devices. The base can be wired and secured to a back-box during building construction, allowing the detector to be installed later, when premises become free of dust and other contaminants. The MRI-4001 and MRI-4002 both have a set of mounting holes covered by the detector head. On the MRI-4001, these are used to mount the base to single gang boxes, 3.5" octagonal boxes, and 4" octagonal boxes. On the MRI-4002, the holes are used to mount the base to 3.5" octagonal boxes. The MRI-4001 has an extra set of outer holes, covered by a removable ring, for 4" square boxes (see figure 2). When the base is secured to the box, the ring is placed back to cover the mounting screws heads. A breakable flat tab in the center of the base can be cut and inserted in the base outer edge then pen marking or a label can then be used to identify the device.

Before installing this device please thoroughly read this manual and refer to the applicable codes for guidance on location, spacing and acceptable use. Also seek guidance from the compatible control panel instructions for the device operation modes and the configuration requirements.

Note: If the detector is used with the remote indicator, then the voltage value of the detector must be at least 18V as the indicators do not operate below 18V.

SPECIFICATIONS

MRI-4001 Dimensions:	6" Diameter, 5/8" Height
MRI-4002 Dimensions:	4" Diameter, 5/8" Height
Wiring range on all terminals:	22 to 12 AWG

FIGURE 1 BASE WIRING

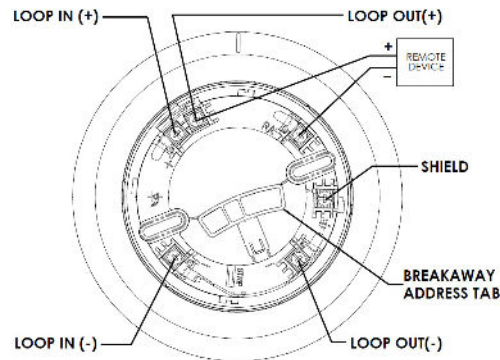

INSTALLATION

The MRI-4001 may be installed over a 4" square, 4" octagonal, 3.5" octagonal, or single gang box. The MRI-4002 may be installed over a 3.5" octagonal box. The mounting may be performed on either the ceiling or the wall. SLC line and remote output connections for the MRI-4001/4002 base are show in figure 1. A twisted pair cable should be used for the SLC line. If a shielded cabled is used, connect the shields to the proper terminal on the base. Do not connect shields to earth ground. If a ground continuity wire is required by the local code, it should be a separate conductor. Please note that shielded cables may reduce the SLC loop length that can be achieved due to their high capacitance.

A breakaway tab inside the base can be inserted in the outer rim of the base to visibly identify each detector with their address. See figures 1, 3, and 5. The detector can then be placed on the base using the following steps:

1. Position the detector centrally on its adapter base ensuring it is level.
2. Rotate clockwise applying gentle pressure. The detector will drop into its keyed location.
3. Continue to rotate clockwise a few degrees until the detector has fully engaged in the adapter base.
4. When the detector is firmly engaged, check the alignment of the raised reference marks on the detector and on the base (figure 4).

See page 2 for instructions on using the anti-tamper feature.

IMPORTANT NOTE ON BASE INSTALLATION

Disconnect loop power before installing the base.

When duplicate terminals are not provided to facilitate monitoring of the installation wiring connections, and there is no provision to prevent looping an unbroken wire around or under a terminal, the word "CAUTION" and the following or equivalent text in letters not less than 2.38 mm (3/32 inch) high shall be included on the installation drawing: "FOR SYSTEM MONITORING - FOR TERMINALS "Loop out (+)" AND "Remote Device (+)", DO NOT USE LOOPED WIRE UNDER TERMINALS. BREAK WIRE RUN TO PROVIDE MONITORING OF CONNECTIONS.

FIGURE 2 BASE MOUNTING:

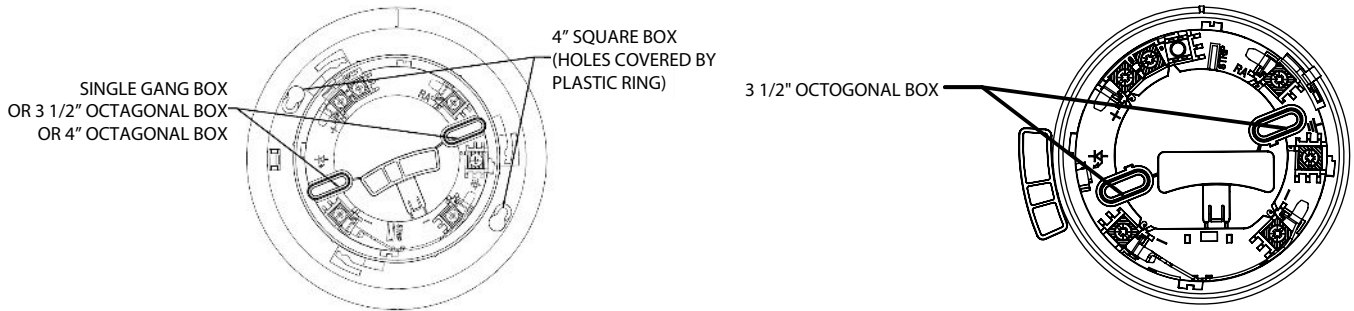

FIGURE 3 HEAD MOUNTING:

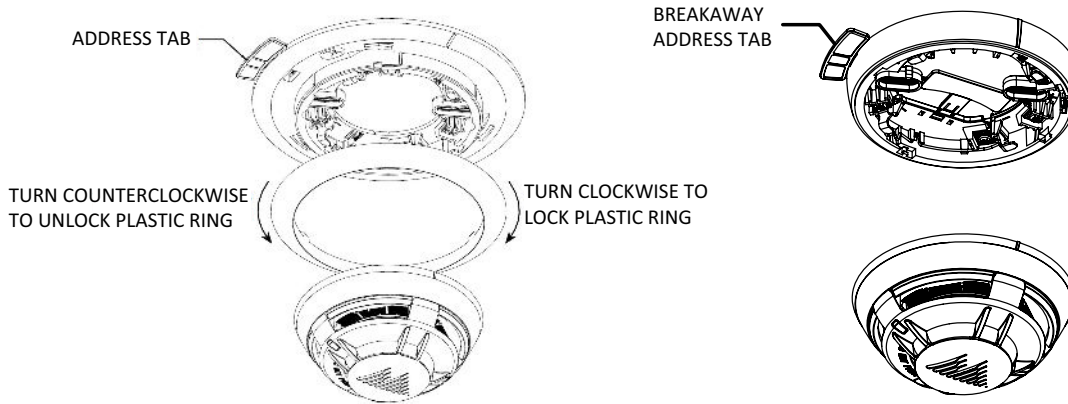

FIGURE 4 ALIGNMENT MARKS:

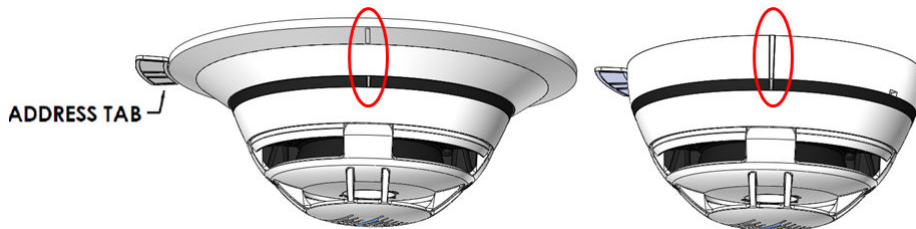
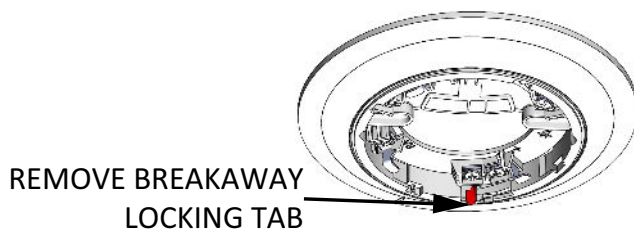
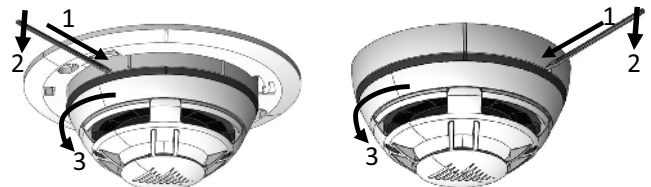

FIGURE 5 TO LOCK THE DETECTOR ON THE BASE:



1. Remove the small breakaway locking tab inside the base (Figure 5).
2. Attach the detector to the base as described in "INSTALLATION" on page 1. You will hear a click when the base is locked in place.

FIGURE 6 TO REMOVE A LOCKED DETECTOR:



1. Insert a thin flathead screwdriver in the slot in the base.
2. Use the screwdriver as a lever to release the locking mechanism by moving the handle in the direction shown in Figure 6.
3. While holding the screwdriver in place, turn the detector counter-clockwise to remove it.