

## MMX-BB-1001WPA / MMX-BB-1001WPRA WEATHER PROTECTED ENCLOSURE



MMX-BB-1001WPRA  
with  
RAM-1032TZDS-CC  
(sold separately)

MMX-BB-1001WPA  
with RAM-1032TZDS-CC  
(sold separately)

### Description

The MMX-BB-1001WP(R)A is a complete enclosure that comes with either a RED or WHITE door, a black back-box, two keys and a durable lock at the top of the door.

The door comes hinged to the bottom side of the box for added weather protection.

The box is capable of handling one RAM-1032TZDS-CC Main Annunciator Chassis which provides up to 32 points of annunciation. RAM-1032TZDS-CC are ordered separately to match the UL installation requirements.

**Note: there is no need for thermostat or heater.**

**RAM-1032TZDS-CC must be ordered separately to match UL installation requirements.**

### Features

- UL Weather Protected, for both indoor and outdoor applications
- White or red semi-gloss finishing, and black back box
- Lexan sealed window, to protect against the challenges of an outdoor application
- Easy to install with 2 Knockouts for wiring, with 7/8" diameter
- For surface mount applications
- Easy to install and maintain: Heater or Thermostat is not needed

### Specifications

Dimensions	Height: 11-5/32" (283mm) Width: 12-15/16" (329mm) Depth: 3-1/2" (89mm)
Rated for Outdoor Environment	+50°C to -40°C (+122°F to -40°F)
Wet Location	95% R.H. @60°C

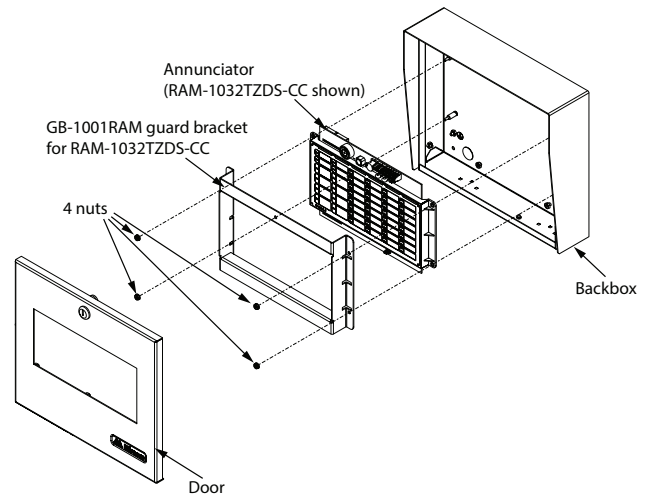

### Ordering Information

Model	Description
MMX-BB-1001WPA	Weather Protected Enclosure - White
MMX-BB-1001WPRA	Weather Protected Enclosure - Red
RAM-1032TZDS-CC	Conformal Coated 32 Zone Remote LED Annunciator with 32 Bi-Coloured Trouble LEDs



This document is provided by Mircom Technologies Ltd., MGC Systems Corp., or their affiliates, subsidiaries and brands, for convenience or marketing only and does not describe products or services technically. For technical information refer to technical manuals. We do not make representations or warranties regarding this information, including as to completeness or accuracy. We may change these contents at any time and reserve all rights in the contents, including copyrights, trademarks and other intellectual property.



#### SECUTRON INC.

Canada 25 Interchange Way, Vaughan (Toronto), Ontario L4K 5W3  
U.S.A. 4575 Witmer Industrial Estates, Niagara Falls, NY 14305  
www.secutron.com

Catalog Number

**1048**  
Issue 2

Tel: (905) 695-3545 Fax: (905) 660-4113  
Tel: (888) 695-3545 Fax: (888) 660-4113